

R&S® ZVA-Zxx MILLIMETERWAVE CONVERTERS

Specifications



Data Sheet
Version 21.00

ROHDE & SCHWARZ

Make ideas real



CONTENTS

Definitions	3
General information	4
Specifications.....	5
Test port	5
Source input (RF IN).....	5
Local oscillator input (LO IN).....	5
Measurement output (MEAS OUT)	6
Reference output (REF OUT)	6
Attenuation control input (ATT), R&S®ZVA-Z110E only.....	6
System characteristics	6
Power supply input	12
General data.....	12
Ordering information	15

Definitions

General

Product data applies under the following conditions:

- Three hours storage at ambient temperature followed by 30 minutes warm-up operation
- Specified environmental conditions met
- Recommended calibration interval adhered to
- All internal automatic adjustments performed, if applicable

Specifications with limits

Represent warranted product performance by means of a range of values for the specified parameter. These specifications are marked with limiting symbols such as $<$, \leq , $>$, \geq , \pm , or descriptions such as maximum, limit of, minimum. Compliance is ensured by testing or is derived from the design. Test limits are narrowed by guard bands to take into account measurement uncertainties, drift and aging, if applicable.

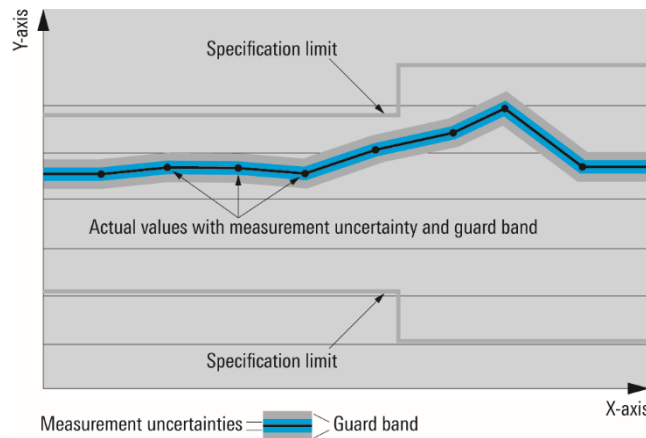

Non-traceable specifications with limits (n. trc.)

Represent product performance that is specified and tested as described under “Specifications with limits” above. However, product performance in this case cannot be warranted due to the lack of measuring equipment traceable to national metrology standards. In this case, measurements are referenced to standards used in the Rohde & Schwarz laboratories.

Specifications without limits

Represent warranted product performance for the specified parameter. These specifications are not specially marked and represent values with no or negligible deviations from the given value (e.g. dimensions or resolution of a setting parameter). Compliance is ensured by design.

Typical data (typ.)

Characterizes product performance by means of representative information for the given parameter. When marked with $<$, $>$ or as a range, it represents the performance met by approximately 80 % of the instruments at production time. Otherwise, it represents the mean value.

Nominal values (nom.)

Characterize product performance by means of a representative value for the given parameter (e.g. nominal impedance). In contrast to typical data, a statistical evaluation does not take place and the parameter is not tested during production.

Measured values (meas.)

Characterize expected product performance by means of measurement results gained from individual samples.

Uncertainties

Represent limits of measurement uncertainty for a given measurand. Uncertainty is defined with a coverage factor of 2 and has been calculated in line with the rules of the Guide to the Expression of Uncertainty in Measurement (GUM), taking into account environmental conditions, aging, wear and tear.

Device settings and GUI parameters are designated with the format “parameter: value”.

Non-traceable specifications with limits, typical data as well as nominal and measured values are not warranted by Rohde & Schwarz.

In line with the 3GPP/3GPP2 standard, chip rates are specified in million chips per second (Mcps), whereas bit rates and symbol rates are specified in billion bits per second (Gbps), million bits per second (Mbps), thousand bits per second (kbps), million symbols per second (Msps) or thousand symbols per second (ksps), and sample rates are specified in million samples per second (Msample/s). Gbps, Mcps, Mbps, Msps, kbps, ksps and Msample/s are not SI units.

General information

The R&S®ZVA-Zxx millimeterwave converters are optional external supplements for the four-port vector network analyzers (R&S®ZVT20, with at least four ports, R&S®ZVA24, R&S®ZVA40, R&S®ZVA50 or R&S®ZVA67), allowing measurements in the frequency range from 50 GHz to 110 GHz. Additional frequency bands are covered by the R&S®ZCxxx millimeterwave converters.

The R&S®ZVA-Zxx millimeterwave converters are available for the frequency bands from:

- 50 GHz to 75 GHz (R&S®ZVA-Z75)
- 60 GHz to 90 GHz (R&S®ZVA-Z90)
- 75 GHz to 110 GHz (R&S®ZVA-Z110 and R&S®ZVA-Z110E).

They consist of a reflectometer module containing a directional coupler, a frequency multiplier for the generation of the source signal, two harmonic mixers as downconverters, and a manually or electronically adjustable attenuator that allows the output power to be varied. In addition, the R&S®ZVA-Z90, as well as the R&S®ZVA-Z110, allows output power setting by adjusting the RF input power.

The four-port network analyzer must be equipped with the R&S®ZVxx-B16 and R&S®ZVA-K8 options.

For the R&S®ZVA-Z110E, the R&S®ZVA-B8 option is additionally recommended.

The R&S®ZVA-Zxx converters come with the following:

- DC power adapter for the input voltage range from 100 V to 240 V (AC) with ± 10 % tolerance
- Hex ball driver
- Two coaxial cables with SMA connectors for the reference and measurement output signals
- Waveguide-to-waveguide adapter acting as test port saver

Specifications

Test port

Frequency range	R&S®ZVA-Z75	50 GHz to 75 GHz
	R&S®ZVA-Z90	60 GHz to 90 GHz
	R&S®ZVA-Z110 and R&S®ZVA-Z110E	75 GHz to 110 GHz
Waveguide designator Electronic Industries Alliance (EIA)	R&S®ZVA-Z75	WR15
	R&S®ZVA-Z90	WR12
	R&S®ZVA-Z110 and R&S®ZVA-Z110E	WR10
Connector type	anti-cocking flange	precision waveguide flange compatible with UG387/U-M
Output power	at +7 dBm input power from the R&S®ZVA	
	R&S®ZVA-Z75	> 0 dBm, 4 dBm (typ.)
	R&S®ZVA-Z90	> 6 dBm, 10 dBm (typ.)
	R&S®ZVA-Z110	> 7 dBm, 10 dBm (typ.)
	R&S®ZVA-Z110E, model .40	
	75 GHz to 95 GHz	> -6 dBm, -3 dBm (typ.)
	95 GHz to 105 GHz	> -8 dBm, -5 dBm (typ.)
	105 GHz to 110 GHz	> -9 dBm, -7 dBm (typ.)
	R&S®ZVA-Z110E, model .50	
	75 GHz to 78 GHz	> -2 dBm, 2 dBm (typ.)
78 GHz to 95 GHz	> 0 dBm, 2 dBm (typ.)	
95 GHz to 110 GHz	> -3 dBm, -1 dBm (typ.)	
Output power attenuation	R&S®ZVA-Z75 manually adjustable	0 dB to 40 dB
	R&S®ZVA-Z90 adjustable by reduction of RF input power	0 dB to 70 dB
	R&S®ZVA-Z110	
	manually adjustable	0 dB to 40 dB
	adjustable by reduction of RF input power	0 dB to 70 dB
Output power frequency response at minimum attenuation (peak-to-peak)	R&S®ZVA-Z110E electronically adjustable	
	R&S®ZVA-Z75 at 0 dB attenuator setting	< 7 dB
	R&S®ZVA-Z90 at +7 dBm RF input power	< 7 dB
	R&S®ZVA-Z110 at 0 dB attenuator setting	< 7 dB
	R&S®ZVA-Z110E at 0 dB attenuator setting	< 7 dB (model .50) < 9 dB (model .40)
Damage level	R&S®ZVA-Z75/-Z90/-Z110/-Z110E	
		+20 dBm

Source input (RF IN)

Connector type	R&S®ZVA-Z75	2.92 mm, female
	R&S®ZVA-Z90	2.92 mm, female
	R&S®ZVA-Z110 and R&S®ZVA-Z110E	2.92 mm, female
Frequency range	R&S®ZVA-Z75	8.333 GHz to 12.5 GHz
	R&S®ZVA-Z90	10 GHz to 15 GHz
	R&S®ZVA-Z110 and R&S®ZVA-Z110E	12.5 GHz to 18.333 GHz
Input power range	R&S®ZVA-Z75	+5 dBm to +10 dBm
	R&S®ZVA-Z90	-15 dBm to +10 dBm
	R&S®ZVA-Z110	-15 dBm to +10 dBm
	R&S®ZVA-Z110E	+4 dBm to +10 dBm

Local oscillator input (LO IN)

Connector type	R&S®ZVA-Z75	2.92 mm, female
	R&S®ZVA-Z90	2.92 mm, female
	R&S®ZVA-Z110 and R&S®ZVA-Z110E	2.92 mm, female
Frequency range	R&S®ZVA-Z75	8.287 GHz to 12.454 GHz
	R&S®ZVA-Z90	9.954 GHz to 14.954 GHz
	R&S®ZVA-Z110 and R&S®ZVA-Z110E	9.34 GHz to 13.715 GHz
Input power range	R&S®ZVA-Z75	+5 dBm to +10 dBm
	R&S®ZVA-Z90	+5 dBm to +10 dBm
	R&S®ZVA-Z110 and R&S®ZVA-Z110E	+5 dBm to +10 dBm

Measurement output (MEAS OUT)

Connector type		SMA, female
Frequency range	R&S®ZVA-Z75	10 MHz to 300 MHz
	R&S®ZVA-Z90	10 MHz to 300 MHz
	R&S®ZVA-Z110 and R&S®ZVA-Z110E	10 MHz to 300 MHz

Reference output (REF OUT)

Connector type		SMA, female
Frequency range	R&S®ZVA-Z75	10 MHz to 300 MHz
	R&S®ZVA-Z90	10 MHz to 300 MHz
	R&S®ZVA-Z110 and R&S®ZVA-Z110E	10 MHz to 300 MHz

Attenuation control input (ATT), R&S®ZVA-Z110E only

Connector type	for connection to the EXTATT CTRL output of the R&S®ZVA vector network analyzer with R&S®ZVA-B8 option	series 711 connector, 3 pins
----------------	--	------------------------------

System characteristics

Trace stability	R&S®ZVA-Z75	< 0.2 dB (typ.) and < 2° (typ.)
	R&S®ZVA-Z90	< 0.2 dB (typ.) and < 2° (typ.)
	R&S®ZVA-Z110 and R&S®ZVA-Z110E	< 0.2 dB (typ.) and < 2° (typ.)
Trace stability is defined as the maximum deviation of the max. or min. hold trace of the reflection factor from its initial (reference) trace when measuring a converter whose waveguide port is terminated with a short. The data is valid if the ambient temperature of the R&S®ZVA/R&S®ZVT20 and the converter has not changed by more than 1 K over 1 hour, the output power of the converter is unattenuated and the measurement bandwidth is set to 100 Hz.		
Source match (without system error correction)	R&S®ZVA-Z75	> 19 dB, > 30 dB (typ.)
	R&S®ZVA-Z90	> 19 dB, > 30 dB (typ.)
	R&S®ZVA-Z110 and R&S®ZVA-Z110E	> 19 dB, > 30 dB (typ.)
Directivity (without system error correction)	R&S®ZVA-Z75	> 23 dB, > 37 dB (typ.)
	R&S®ZVA-Z90	> 23 dB, > 30 dB (typ.)
	R&S®ZVA-Z110	> 23 dB, > 30 dB (typ.)
	R&S®ZVA-Z110E	
	75 GHz to 105 GHz	> 23 dB, > 30 dB (typ.)
105 GHz to 110 GHz	> 19 dB, > 25 dB (typ.)	
Effective source match (with system error correction)	R&S®ZVA-Z75	> 35 dB (meas.)
	R&S®ZVA-Z90	> 35 dB (meas.)
	R&S®ZVA-Z110 and R&S®ZVA-Z110E	> 35 dB (meas.)
Effective directivity (with system error correction)	R&S®ZVA-Z75	> 35 dB (meas.)
	R&S®ZVA-Z90	> 35 dB (meas.)
	R&S®ZVA-Z110 and R&S®ZVA-Z110E	> 35 dB (meas.)
Dynamic range	R&S®ZVA-Z75	> 90 dB, 110 dB (typ.)
	R&S®ZVA-Z90	> 100 dB, 115 dB (typ.)
	R&S®ZVA-Z110	> 100 dB, 110 dB (typ.)
	R&S®ZVA-Z110E, model .40	
	75 GHz to 110 GHz	> 90 dB, 105 dB (typ.)
	R&S®ZVA-Z110E, model .50	
	75 GHz to 78 GHz	> 100 dB, 110 dB (typ.)
	78 GHz to 95 GHz	> 105 dB, 115 dB (typ.)
95 GHz to 110 GHz	> 95 dB, 110 dB (typ.)	
Dynamic range is defined as the difference between the data trace of the transmission magnitude with maximum test port output power and both test ports through-connected on the one hand and the RMS value of the data trace of the transmission magnitude produced by noise and crosstalk with test ports short-circuited on the other. The specification is valid without system error correction and at 10 Hz measurement bandwidth. The dynamic range can be increased by using a measurement bandwidth of 1 Hz.		

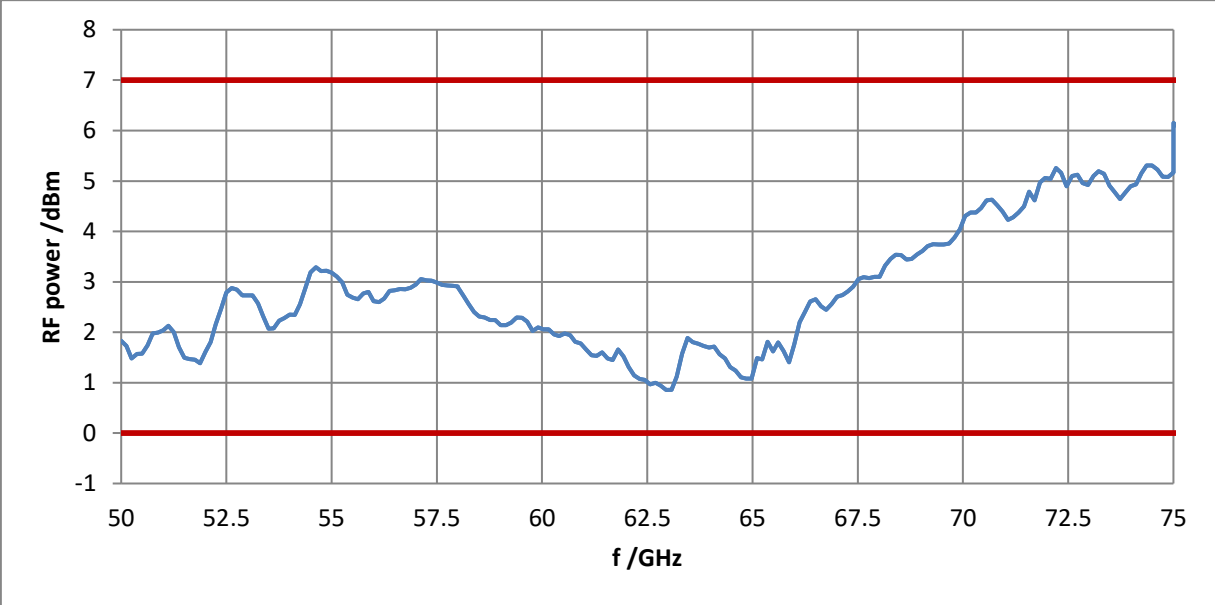

Test port output power versus frequency of the R&S®ZVA-Z75

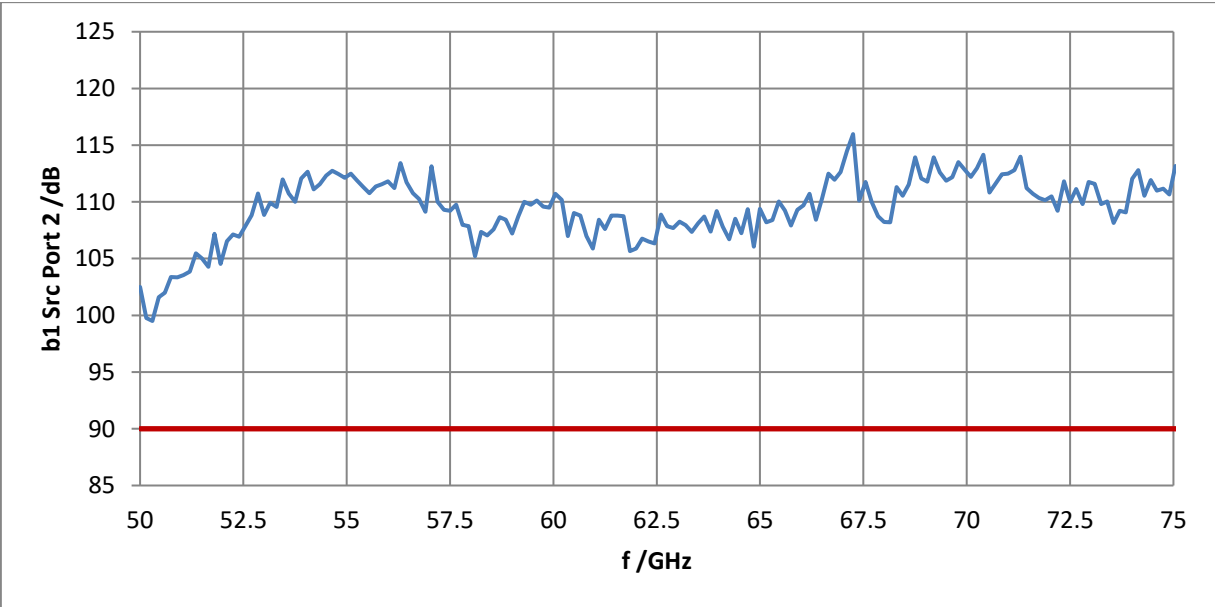

Dynamic range in dB versus frequency of the R&S®ZVA-Z75

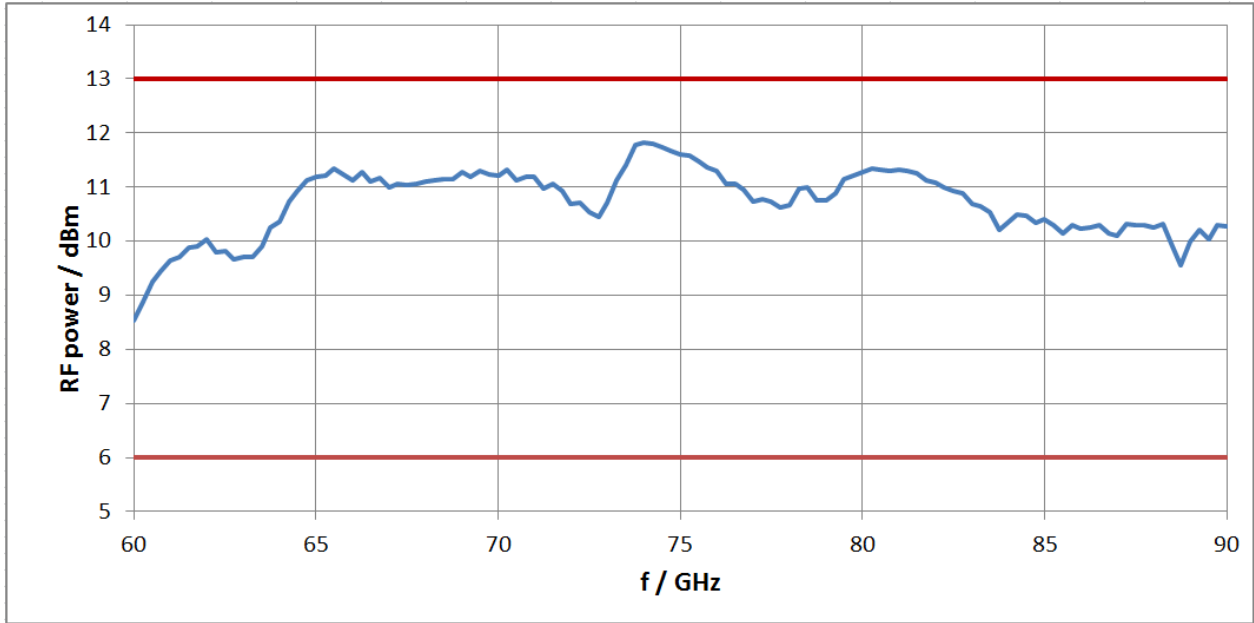

Test port output power versus frequency of the R&S®ZVA-Z90

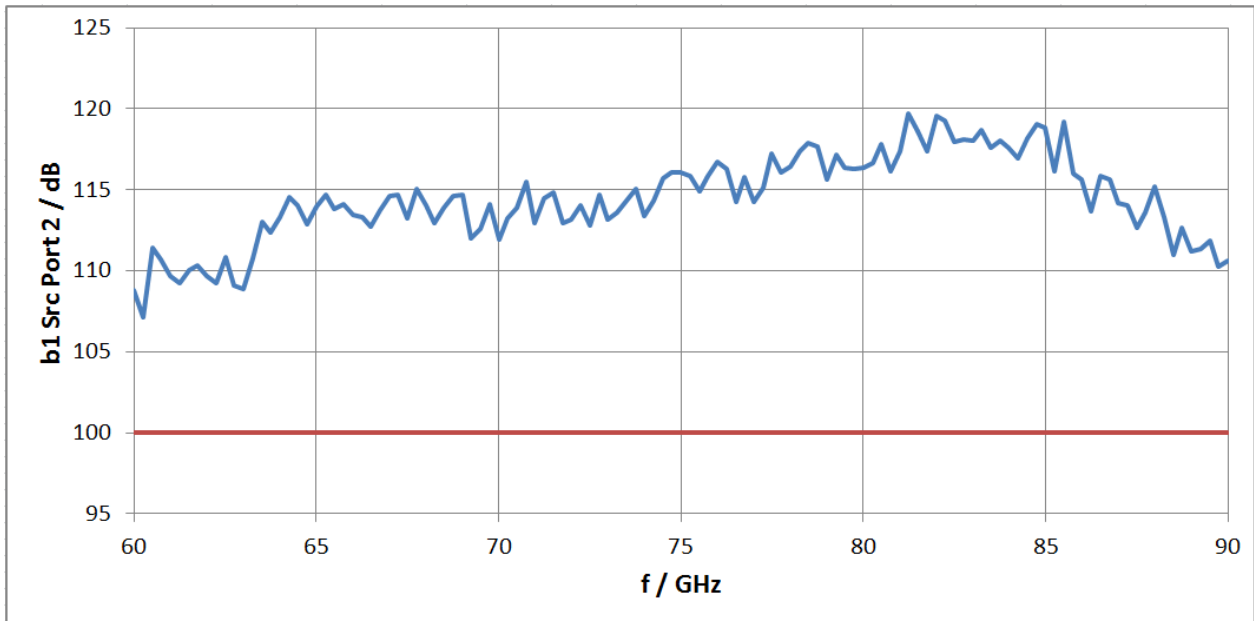

Dynamic range in dB versus frequency of the R&S®ZVA-Z90

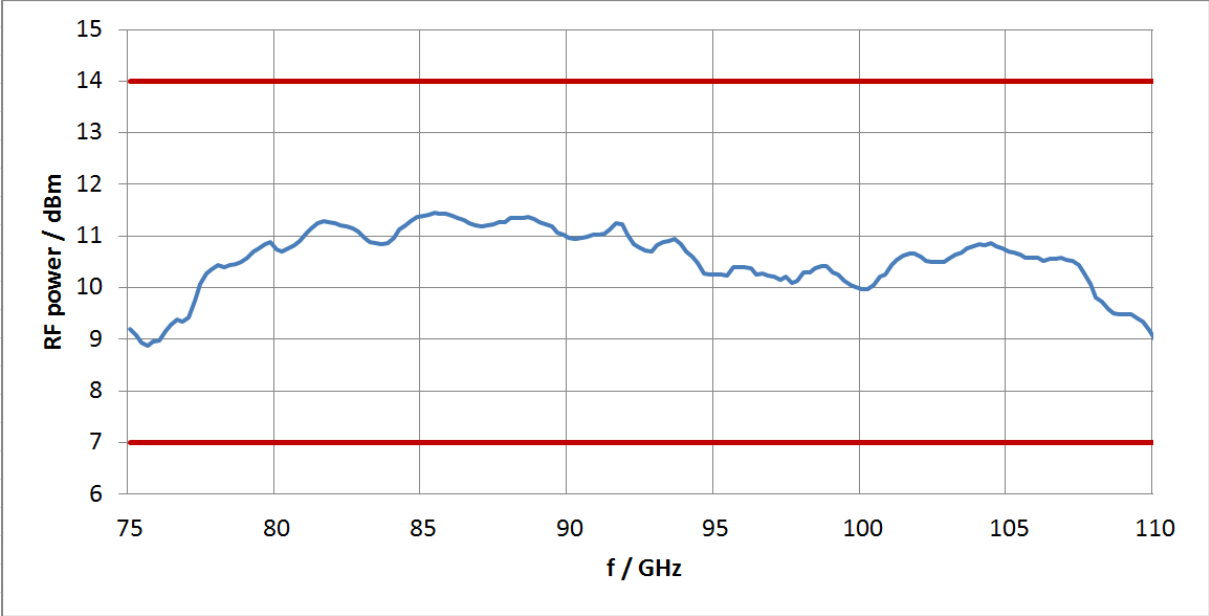

Test port output power versus frequency of the R&S®ZVA-Z110

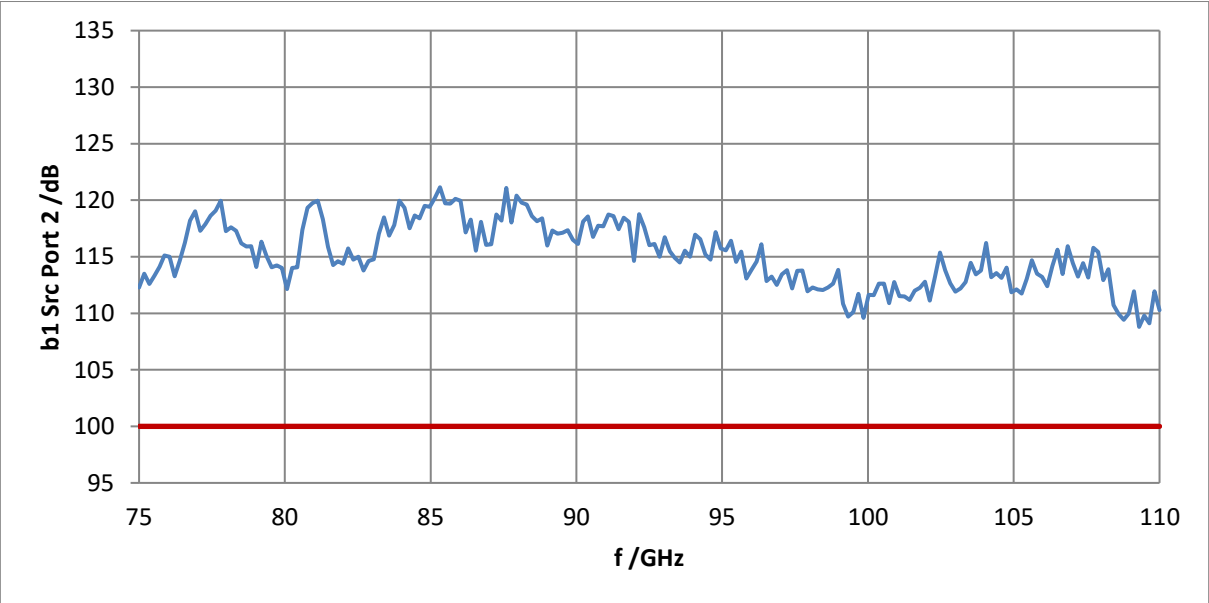

Dynamic range in dB versus frequency of the R&S®ZVA-Z110

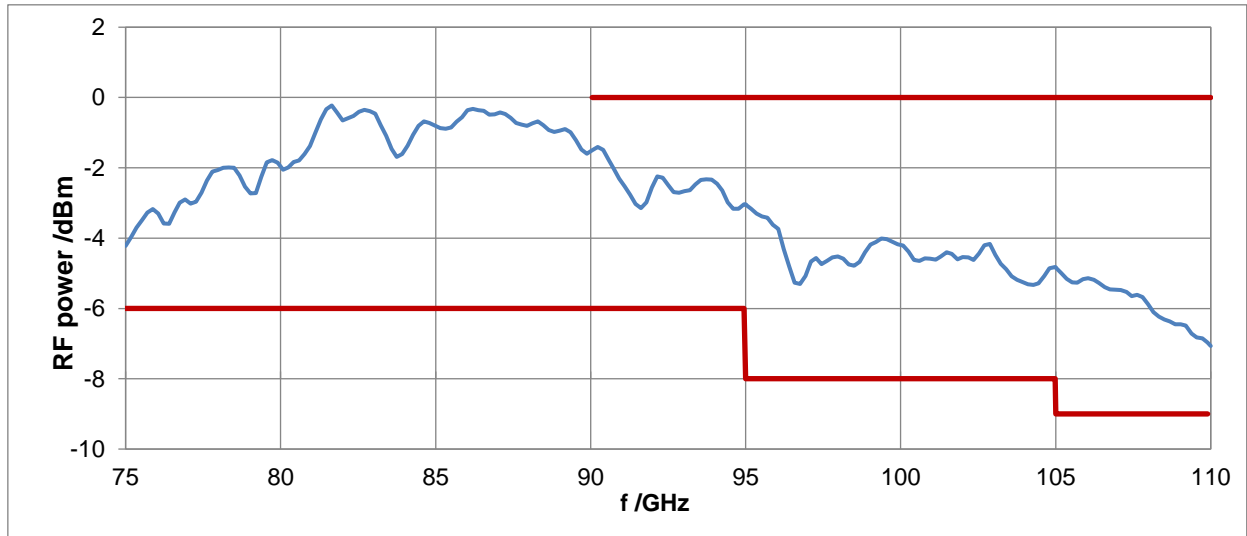

Test port output power versus frequency of the R&S®ZVA-Z110E (model .40)

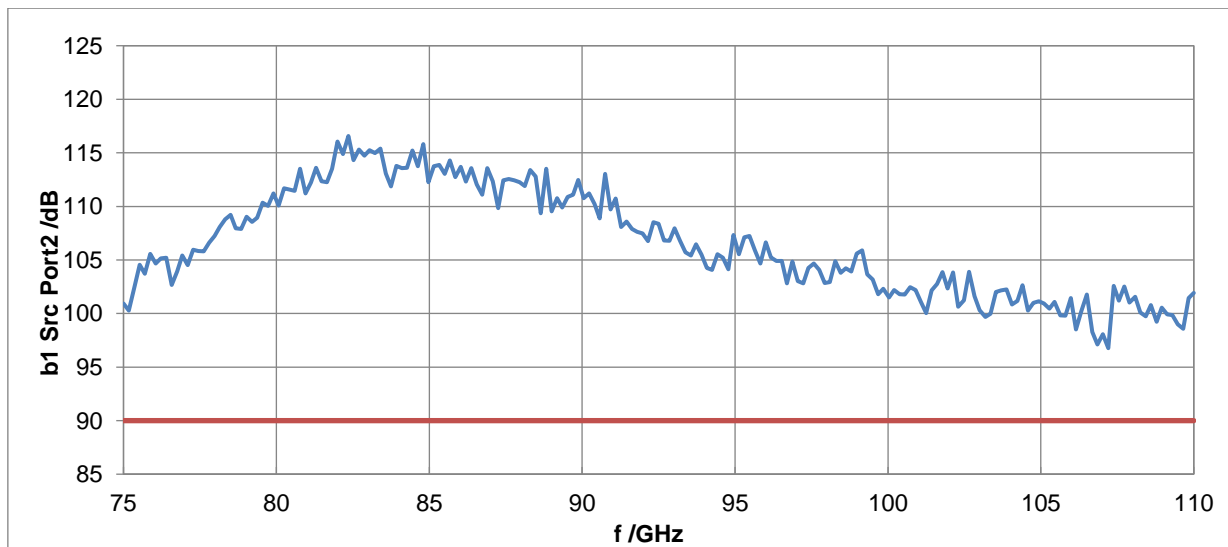

Dynamic range in dB versus frequency of the R&S®ZVA-Z110E (model .40)

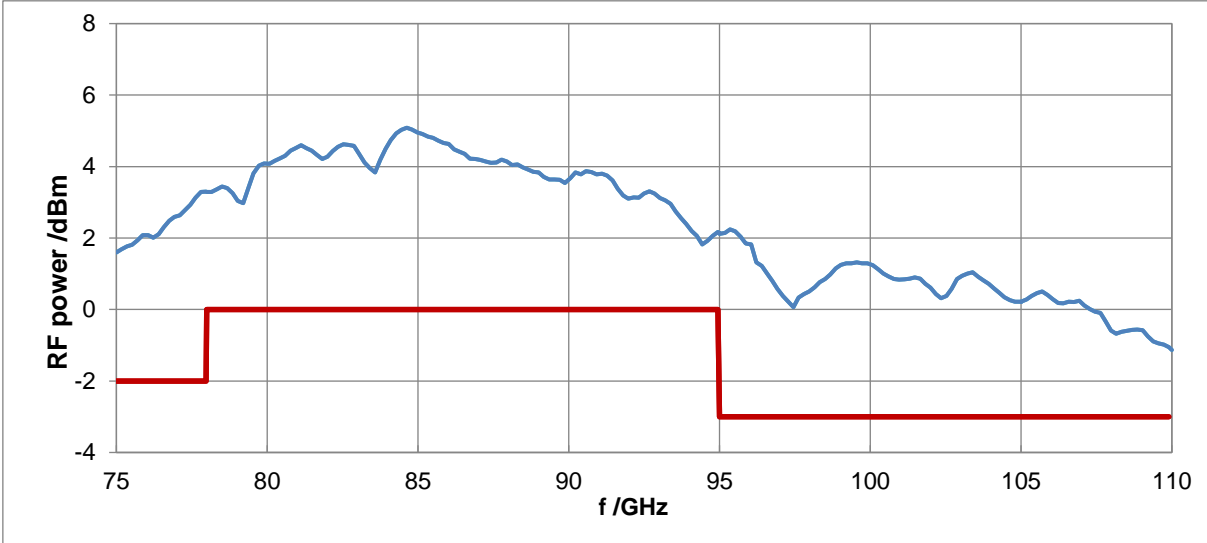

Test port output power versus frequency of the R&S®ZVA-Z110E (model .50)

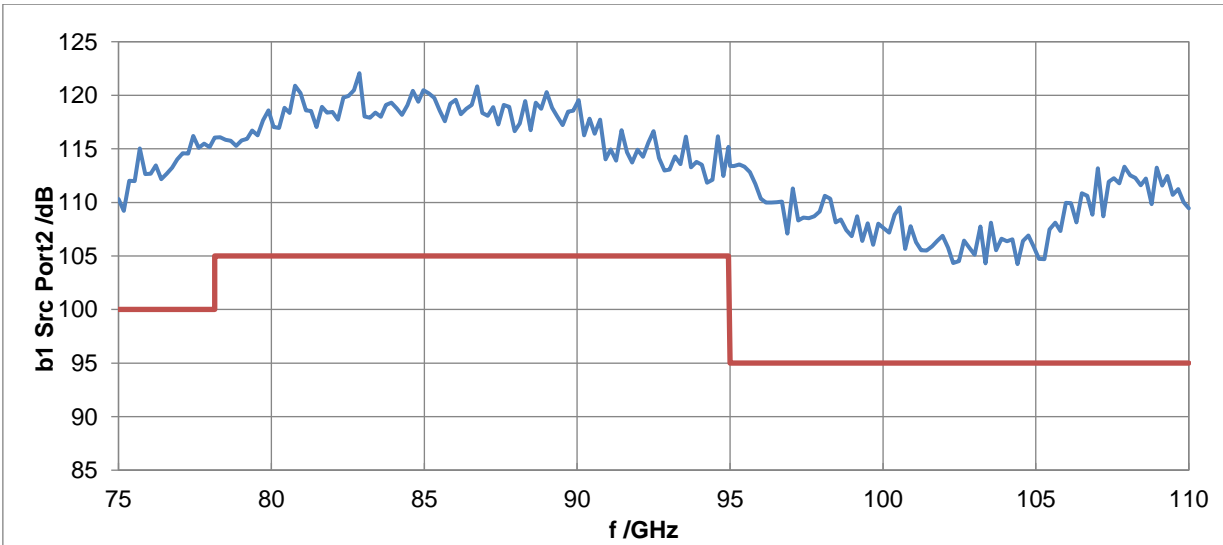

Dynamic range in dB versus frequency of the R&S®ZVA-Z110E (model .50)

Power supply input

Connector type		DIN 45323 power connector
Voltage		+9 V ± 540 mV
Current	R&S®ZVA-Z75/R&S®ZVA-Z90/ R&S®ZVA-Z110/R&S®ZVA-Z110E	< 1.1 A

General data

Temperature loading	operating temperature range	+18 °C to +28 °C
	permissible temperature range	+5 °C to +40 °C
	storage temperature range	-40 °C to +70 °C
Damp heat		in line with IEC 60068-2-1 and IEC 60068-2-2
		+40 °C at 80 % rel. humidity, in line with IEC 60068-2-30
Mechanical resistance	vibration, sinusoidal	5 Hz to 150 Hz, in line with IEC 60068-2-6
	vibration, random	10 Hz to 300 Hz, in line with IEC 60068-2-64
	shock	40 g shock spectrum, in line with IEC 60068-2-27, MIL-STD-810
Dimensions (W × H × D)	with feet height adjusted to 12.1 mm (0.5 in)	
	R&S®ZVA-Z75	413 mm × 110 mm × 114 mm (16.3 in × 4.3 in × 4.5 in)
	R&S®ZVA-Z90	286 mm × 78 mm × 114 mm (11.3 in × 3.1 in × 4.5 in)
	R&S®ZVA-Z110 and R&S®ZVA-Z110E	361 mm × 110 mm × 114 mm (14.2 in × 4.3 in × 4.5 in)
Number of feet	alternatively	3 or 4
Feet height	user-adjustable	12.1 mm to 29.1 mm (0.5 in to 1.1 in)
Weight		3 kg (7 lb)
Shipping weight		5 kg (11 lb)

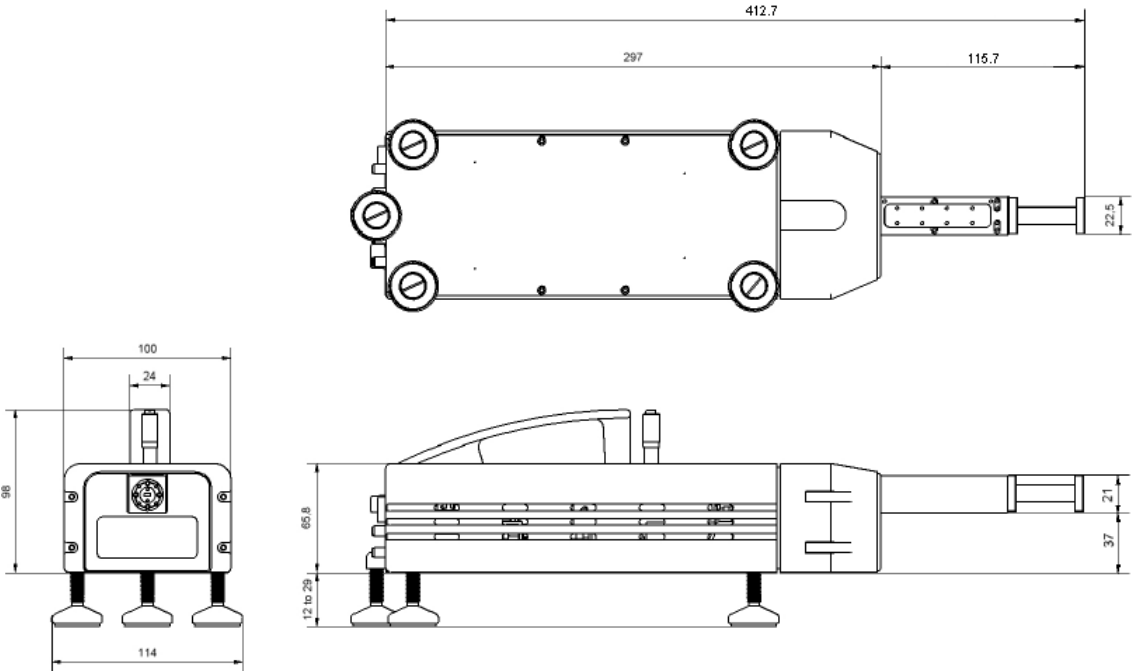

Dimensions (in mm) of the R&S®ZVA-Z75

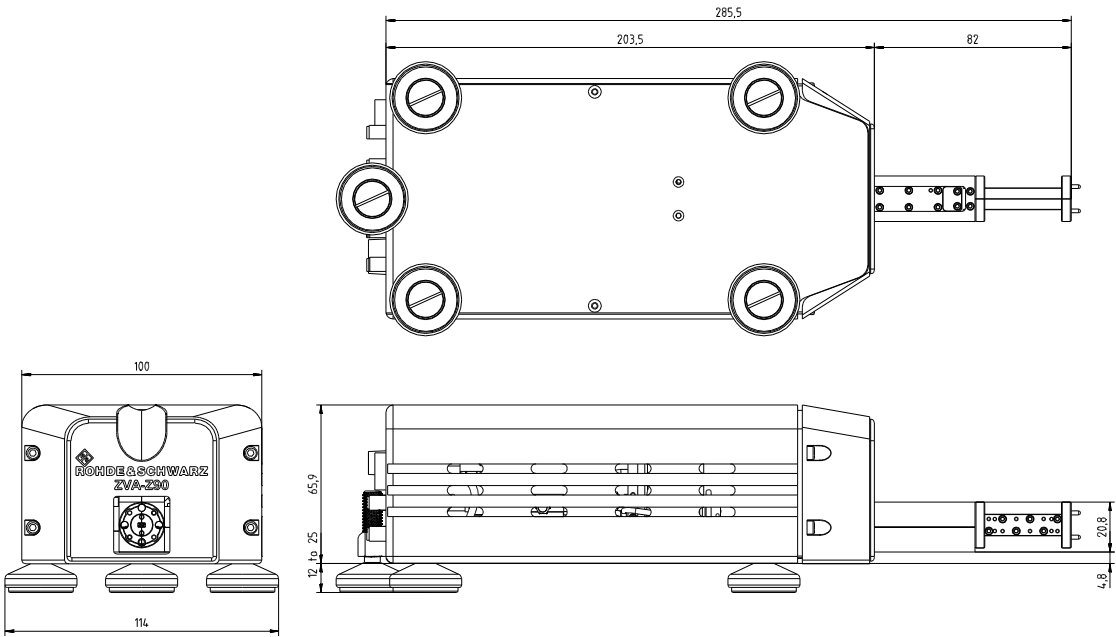

Dimensions (in mm) of the R&S®ZVA-Z90

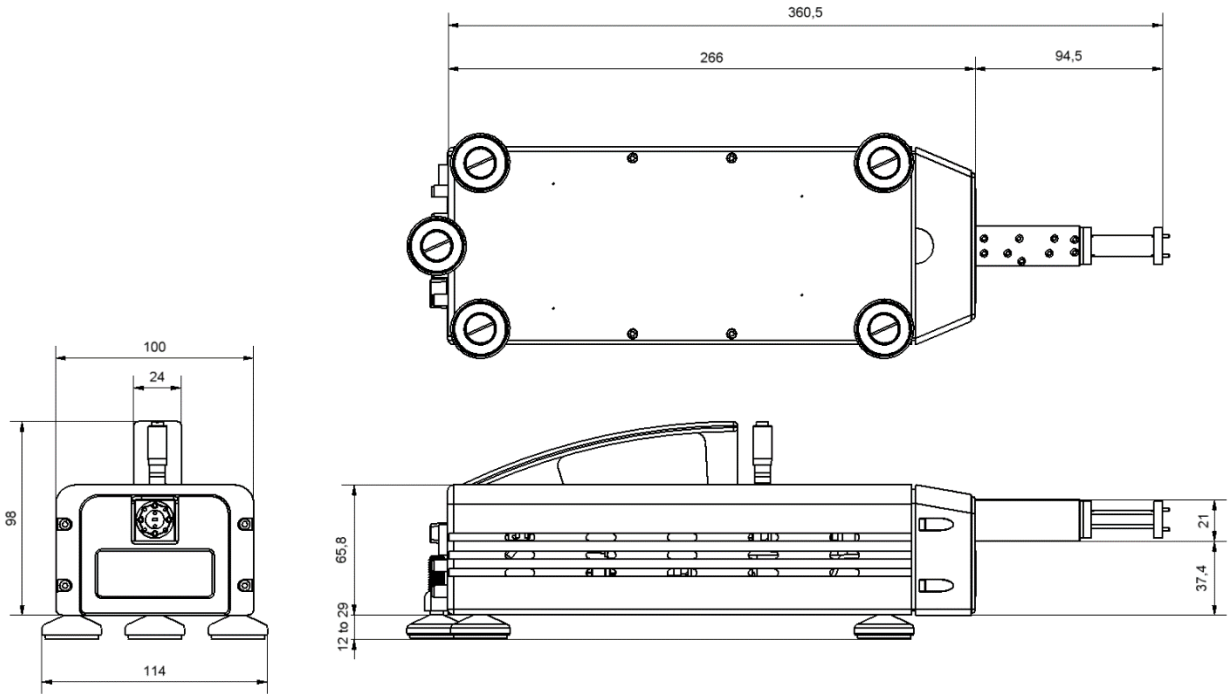

Dimensions (in mm) of the R&S®ZVA-Z110

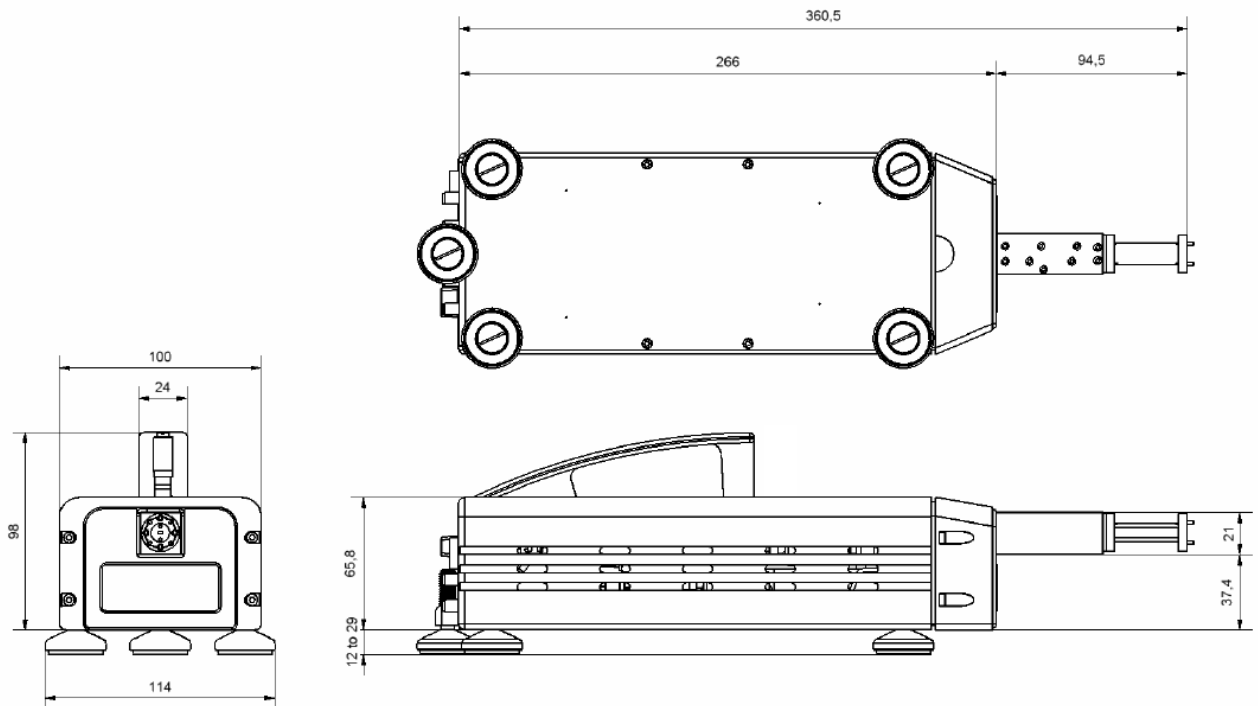

Dimensions (in mm) of the R&S®ZVA-Z110E

Ordering information

Designation	Type	Order No.
Converter WR15	R&S®ZVA-Z75	1307.7400.02
Converter WR12	R&S®ZVA-Z90	1322.3024.02
Converter WR10	R&S®ZVA-Z110	1307.7000.03
Converter EL ATT WR10	R&S®ZVA-Z110E	1307.7000.40
Converter EL ATT WR10 HP	R&S®ZVA-Z110E	1307.7000.50
Test cable 3.5 mm (f) to 3.5 mm (m), 910 mm (two cables per converter required)	R&S®ZV-Z193	1306.4520.36
Test cable 2.92 mm (f) to 2.92 mm (m), 910 mm (two cables per converter required)	R&S®ZV-Z195	1306.4536.36
Waveguide calibration kit WR15 (without sliding matches)	R&S®ZV-WR15	1307.7500.30
Waveguide calibration kit WR15 (with sliding match)	R&S®ZV-WR15	1307.7500.31
Waveguide calibration kit WR12 (without sliding matches)	R&S®ZV-WR12	1307.7700.10
Waveguide calibration kit WR12 (with sliding match)	R&S®ZV-WR12	1307.7700.11
Waveguide calibration kit WR10 (without sliding matches)	R&S®ZV-WR10	1307.7100.10
Waveguide calibration kit WR10 (with sliding match)	R&S®ZV-WR10	1307.7100.11
External attenuator control for R&S®ZVA-Z110E	R&S®ZVA-B8	1307.6026.02
Converter control software	R&S®ZVA-K8	1307.7022.02

Service options		
Extended warranty, one year	R&S®WE1	Please contact your local Rohde & Schwarz sales office.
Extended warranty, two years	R&S®WE2	
Extended warranty, three years	R&S®WE3	
Extended warranty, four years	R&S®WE4	
Extended warranty with calibration coverage, one year	R&S®CW1	
Extended warranty with calibration coverage, two years	R&S®CW2	
Extended warranty with calibration coverage, three years	R&S®CW3	
Extended warranty with calibration coverage, four years	R&S®CW4	

Extended warranty with a term of one to four years (WE1 to WE4)

Repairs carried out during the contract term are free of charge ¹. Necessary calibration and adjustments carried out during repairs are also covered. Simply contact the forwarding agent we name; your product will be picked up free of charge and returned to you in top condition a couple of days later.

Extended warranty with calibration (CW1 to CW4)

Enhance your extended warranty by adding calibration coverage at a package price. This package ensures that your Rohde & Schwarz product is regularly calibrated, inspected and maintained during the term of the contract. It includes all repairs ¹ and calibration at the recommended intervals as well as any calibration carried out during repairs or option upgrades.

¹ Excluding defects caused by incorrect operation or handling and force majeure. Wear-and-tear parts are not included.

Service that adds value

- ▶ Worldwide
- ▶ Local und personalized
- ▶ Customized and flexible
- ▶ Uncompromising quality
- ▶ Long-term dependability

Rohde & Schwarz

The Rohde&Schwarz electronics group offers innovative solutions in the following business fields: test and measurement, broadcast and media, secure communications, cybersecurity, monitoring and network testing. Founded more than 80 years ago, the independent company which is headquartered in Munich, Germany, has an extensive sales and service network with locations in more than 70 countries.

www.rohde-schwarz.com

Sustainable product design

- ▶ Environmental compatibility and eco-footprint
- ▶ Energy efficiency and low emissions
- ▶ Longevity and optimized total cost of ownership

Certified Quality Management

ISO 9001

Certified Environmental Management

ISO 14001

Rohde & Schwarz training

www.training.rohde-schwarz.com

Rohde & Schwarz customer support

www.rohde-schwarz.com/support

